

SKYLINE II

Replication Line for CD & DVD 5



SINGULUS 

SKYLINE II

Replication Line for CD & DVD 5

The SKYLINE II Duplex Replication Line from SINGULUS TECHNOLOGIES covers the production of CD and DVD 5. With the installation of over 1900 systems to date, the SKYLINE is the industry benchmark.

The upgraded SKYLINE II combines CD and DVD 5. A built-in pushbutton function to switch from CD to DVD 5 and back is standard. This machine achieves the most cost-efficient disc production and highest product quality and yield available in the market.

The SKYLINE II is equipped with one molding machine, one SINGULUS V metallizer, one spin-off bowl (two for DUPLEX), a UV-curing device and an inspection system for quality assurance of the finished discs.

The SINGULUS V is our latest optical disc metallizer and has been part of our product line for several years. The high performance of this metallizer significantly contributes to the increased reliability, maximum uptime and easy maintenance of the SKYLINE II.

With many patented original parts, the SKYLINE II ensures a high daily production of CD & DVD. With the worldwide sales and service network of SINGULUS TECHNOLOGIES, we are able to offer exceptional support and technological synergies to benefit our customers.



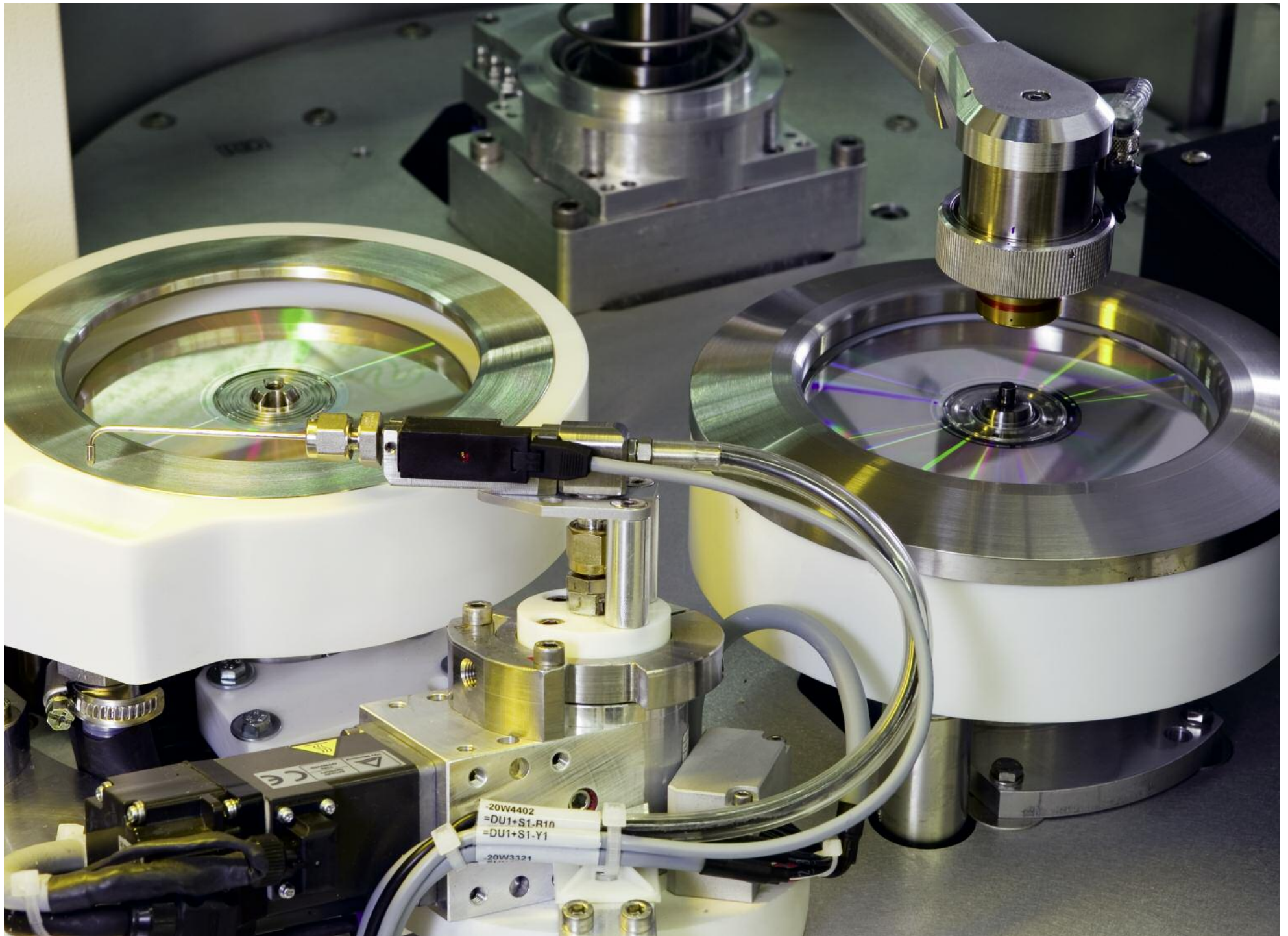

Main Characteristics



- _ Able to produce CD-Audio / CD-Video, CD-ROM
- _ Available upgrades for DVD 5
- _ Modular, highly integrated design
- _ All production steps from molding, metallizing, bonding, UV-curing to final quality inspection included
- _ Minimum space required

- _ Integration of the established SINGULUS V metallizer
- _ Production cycle time including molding ≤ 3.3 seconds for CD and ≤ 6.0 seconds for DVD 5 (depending on molding equipment)
- _ Discs downstream ≤ 2.5 seconds for CD and ≤ 5.6 seconds for DVD 5

- _ Entire machine including electric rack mounted on a base frame
- _ Clear structured disc flow with automated handling of CDs (DVDs) through all production steps
- _ Excellent maintenance and service accessibility

Main Components

1 Injection Molding

The injection molding machine is equipped with molds that are specially designed for molding of CDs and DVDs from polycarbonate (PC) of adequate quality. The injection molding machine is equipped with its own computer control unit and is fully integrated into SKYLINE II and interfaced with the PLC.

2 Cooling Conveyor

The high take-out temperatures generated by fast cycling molding machines make it necessary to cool down the discs before further processing. Therefore, SKYLINE II has an integrated cooling conveyor with 13 positions between each delivery point, from the molding machine take-out robot to the sputter module transfer position.

3 Sputter Station

One important feature of the SKYLINE II is the integration of the SINGULUS V high rate sputter equipment. The high performance of this metallizer significantly contributes to the increased reliability, high uptime and quick repair times of the SKYLINE II. The system is equipped with one energy-saving,

high performance FOCUS Cathode® achieving the specified layer characteristics for the metallization of CD and DVD 5 layers.

4 Spin-Off Units

The first spin-off bowl is used to rotate the disc while dispensing the lacquer or bonding resin. For CD production, the protective lacquer is distributed with high uniformity by means of spin-off. In DVD 5 mode, the bonding resin is dispensed onto the bottom disc half, then the top side disc is smoothly placed onto the resin. In the SKYLINE II DUPLEX, a second spin-off bowl is integrated next to the first one. This second bowl, with its assortment of spinning speeds, is used to ensure high uniformity of the bonding agent between the disc halves.

5 Bonding (DUPLEX only)

The bonding unit consists of a dosing system with a degassing unit, two spin-off bowls and an I-BOND® system, guaranteeing the prevention of bubble generation during the bonding process.

6 UV-Curing

The UV-curing station has a two-position turntable. The rotation of the disc in front of the UV-bulb guarantees a constant and uniform curing of the CD or DVD 5 as well as excellent curing results for the DVD 5 disc edge.

7 Final Inspection

The SKYLINE II is equipped with a high quality final inspection system for CD; the SKYLINE II DUPLEX has a different scanner for the inspection of DVD5.

8 Control Unit

The SKYLINE II is controlled through one Siemens S7 and one Mitsubishi PLC. With a 15" touch screen, the visualization concept helps the operators to become rapidly accustomed to the operation of the whole line.

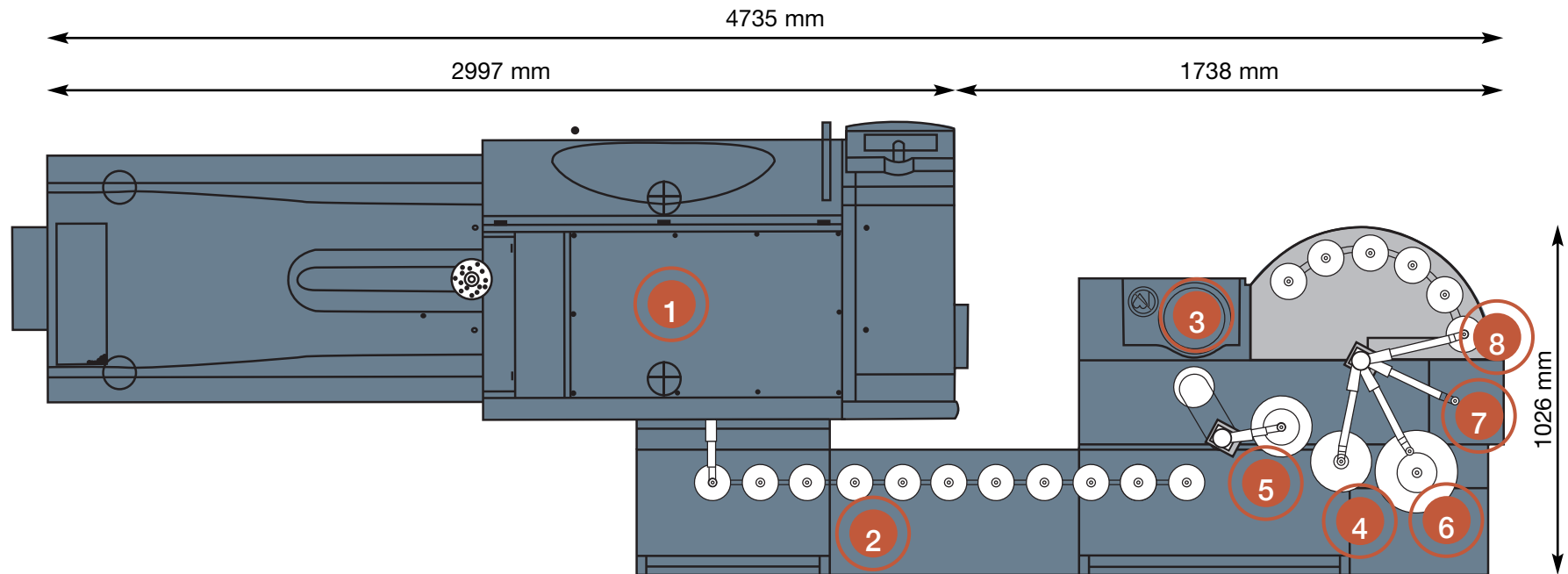

Product	
	CD-Audio, CD-ROM (Options: CD-Card, DVD 5)
- Diameter:	120 mm (80 mm media on request)
- Thickness:	1.2 mm +/- 0.1
- Material:	Polycarbonate (PC)
- Metallization:	Aluminum
- Resin:	qualified protective lacquers or bonding agents for UV-curing

Product Cycle Time	
- Total cycle time:	≤ 3.3 s CD ≤ 6.0 s DVD 5 (depending on molding equipment)
- Dry cycle time CD:	≤ 2.5 s (one spin bowl)
- Dry cycle time DVD 5:	≤ 5.6 s (two spin bowls)

Target Lifetime	
- CD (Al):	up to 200,000 at 55 nm thickness
- DVD 5 (Al):	up to 250,000 at 40 nm thickness



Headquarters

SINGULUS TECHNOLOGIES AG
Hanauer Landstrasse 103
D - 63796 Kahl, Germany
Tel. +49 6188 440-0
Fax +49 6188 440-1130
sales@singulus.de
www.singulus.de

Production Site for Wet Processing Systems

SINGULUS TECHNOLOGIES AG
Branch Office Fuerstenfeldbruck
Fraunhoferstr. 9
82256 Fuerstenfeldbruck,
Germany
Tel. +49 8141 3600-0
Fax +49 8141 3600-2100
sales@singulus.de

Subsidiaries

China
SINGULUS TECHNOLOGIES CHINA
Room B412-413,
No. 1400 Jiangchang Road,
Jingan District, Shanghai, China
Zip Code: 200072
Tel. +86 13916990710

Tel. +86 13916990710
Contact: Greens Pan
Tel. +86 13822138376
greens.pan@singulus.com.cn

Contact: Michael Han
Tel. +86 13917382315
michael.han@singulus.cn

France
SINGULUS TECHNOLOGIES
FRANCE S.A.R.L.
Tel. +33 3 893111-29
singulus@club-internet.fr

Latin America
SINGULUS TECHNOLOGIES
LATIN AMERICA LTDA.
Tel. +55 1121 6524-10
sales@singulus.com.br

Singapore/South East Asia
SINGULUS TECHNOLOGIES
ASIA PACIFIC PTE LTD.
Tel. +65 674 119-12
sales@singulus.com.sg

Taiwan
SINGULUS TECHNOLOGIES
TAIWAN LTD.
Tel. +886 2 8692-6996
sales@singulus.com.tw

United States, Mexico and Canada
SINGULUS TECHNOLOGIES INC.
Tel. +1 860 68380-00
sales@singulus.com

SINGULUS 